



武汉中原长江科技发展有限公司
(国营第七五二厂)

SPECIFICATION OF PRODUCT

Cylindrical Li/ MnO₂ Primary Cell

Model : CR34615

Executing Date : 2021-01-20

Document No.	Q/VG.1.015 - 2021		Drawing No.	VG430.029	
Originator		Checked By		Approved By	

Tel : +86-27-84732172

Fax : +86-27-84732186

Http: //www.100752.com

Email : Sunmoon_Battery@hotmail.com

Address : No.231, Xingsan Road, Hannan District, Wuhan, Hubei Province, China



1 Scope

This Product Specification describes the technique requirements, test procedure and precaution notes of Cylindrical Li/SOCI₂ Primary Cell CR34615 and battery pack to be supplied to customer by Wuhan Sunmoon Battery Co., Ltd.

2 Specification

Chart 1

Item	Parameter	Notes
Nominal Voltage	3.00 V	
Nominal Capacity	12.0Ah At 23°C±2°C,10mA discharge to cut off voltage 2.0V)	Capacity is related to discharge current, working temperature and cut off voltage.
Working temperature	-40°C ~ +70°C	If the working temperature is higher or lower than RT, the capacity and primary pulse will be lower.
Maximum Constant discharge current	2500mA	If need larger current, pls contact Wuhan Sunmoon Battery Co., Ltd.
Maximum Pulse discharge current	6000mA	If need larger current, pls contact Wuhan Sunmoon Battery Co., Ltd.
Maximum measurement	Diameter :34.2 mm ,Height :61.5 mm	No special package, no wire, no pin, only single battery.
Maximum Weight	130g	No special package, no wire, no pin, only single battery.
Storage life	6 Years	Stored under specified condition.
Annual capacity lost	≤2%	Stored under specified condition.
Storage condition	Batteries shall be stored in a dry, ventilated and clean warehouse with temperature below 30°C and relative humidity no more than 75%. Batteries shall be stored away from heat sources and shall not be put together with inflammable, explosive, acid, alkali or other corrosive substances.	If need higher temperature, pls contact Wuhan Sunmoon Battery Co., Ltd.

3 Dimension

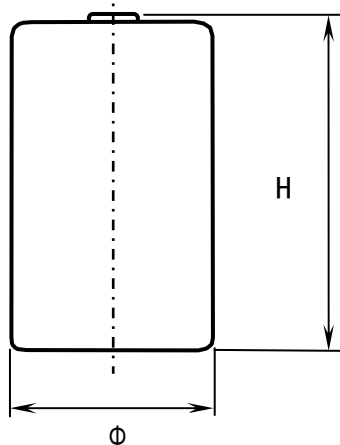



4 Electrical Characteristics and testing method

4.1 Appearance and Dimension

表 2/Chart 2

Testing item	Testing Method	Testing Standard
Appearance	Under daylight conditions, check the battery with eyes.	Clean appearance clear label no scratches no deformation, rust, leakage etc.
Measurement	Use a vernier caliper with a measurement error of not more than 0.02mm for testing. In order to prevent battery short circuit, a layer of insulating material should be pasted on the caliper head.	All dimensions meet the requirements.

4.2 电性能

表 3/Chart 3

Testing item	Testing Method	Testing Standard
Open circuit voltage	Measure with three and a half digital voltmeter.	$\geq 3.0V$ ($23^{\circ}C \pm 2^{\circ}C$)
Load voltage	Measure with three and a half digital voltmeter, resistance 7.5Ω , time $\leq 5s$.	$\geq 2.75V$ ($23^{\circ}C \pm 2^{\circ}C$)
Rapid discharge	100mA, $23^{\circ}C \pm 2^{\circ}C$ constant discharge to 2.0V.	$\geq 9.80Ah$
Normal discharge	20mA, $23^{\circ}C \pm 2^{\circ}C$ constant discharge to 2.0V.	$\geq 11.50Ah$
High temperature discharge	Store for 16 hours at $55^{\circ}C \pm 2^{\circ}C$, 20mA, $55^{\circ}C \pm 2^{\circ}C$ constant discharge to 2.0V.	$\geq 10.81Ah$
Low temperature discharge	Store for 16 hours at $55^{\circ}C \pm 2^{\circ}C$, 20mA, $55^{\circ}C \pm 2^{\circ}C$ constant discharge to 2.0V.	$\geq 7.50Ah$

Remark :

If battery or battery pack in series with diode, the load voltage will be 0.4V lower while testing.

For fast and regular discharge detection, the voltage platform will be slightly different.

The open circuit voltage and load voltage of the battery (pack) must be tested according to chart 3 above before use.

Before installing the battery (pack), it is necessary to use another alternative power supply to connect to the circuit to check whether the power consumption of the circuit board is normal; do not damage the battery package during installation to cause a short circuit.

If there are other power sources in the battery (group) use circuit, an anti-recharge device must be designed in the circuit to isolate the external power source and the lithium battery to prevent the battery from being



charged. Please communicate with our company for details.

The use circuit needs to set the battery (group) discharge termination voltage, that is, when the battery (group) is working, the load is lower than $2.0V \cdot n$ (the number of batteries in series), and the battery power supply circuit should be cut off to prevent the battery from over-discharging and causing safety hazards.

Do not put the battery upside down.

If the battery is used in combination, the protection circuit shall refer to the following protection circuit diagram:

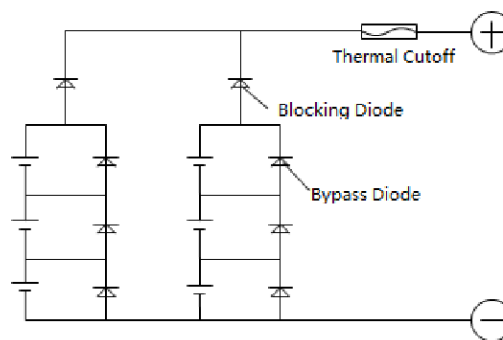

4.3 Environment Adaptability

Chart 4

Testing Item	Testing Method	Testing Standard
Low Frequency Vibration	Firmly fix the battery on the vibrating table, apply a simple harmonic vibration with an amplitude of 0.8mm (double amplitude of 1.6mm), frequency change rate of 1Hz/min, frequency range of (10 ~ 55) Hz. After 95min±5min vibration in axial and radial directions, take out the battery and test the open circuit voltage in 3 minutes.	The open-circuit voltage conforms to chart 3 and the battery does not explode, fire or leak.
Fall	Divide the test batteries into two parts, keep half of them in the test box at the temperature -30°C and the other half 55°C for at least 4h. And then take out the batteries and drop each batteries once from height of 76cm±5cm to a hard concrete surface in 10mins, the axial plane should be parallel to the concrete plane while dropping.	
Low pressure	Keep the battery in the vacuum test chamber with pressure 11.6kPa and temperature 25°C±2°C for 6 hours and observe the battery.	
Strike	Firmly fix the battery on the test table, conduct an equal amplitude strike test in both axial and radial directions. The lowest average acceleration within the first 3ms reach 735m/s ² and the peak acceleration 1225m/s ² ~ 1715m/s ² . After the test, detect the open circuit voltage and observe the battery.	



4.4 安全性能

Chart 5

Testing Item	Testing Method	Testing Standard
Short circuit test	Keep the temperature of battery shell at 55°C and short circuit the battery externally at this temperature. The total impedance should be less than 0.1 Ω . Keep short circuit the battery until the temperature of battery cell is back to 55°C and then keep short circuit the battery for at least 1h. Observe the battery for 6h.	No rupture, no explosion, no fire, and the surface temperature of the battery does not exceed 170°C.
Charge test	Connect the battery with a 12V DC power supply in the reverse direction and in series with 140 Ω resistance, charge for 354h and observe the battery.	Allow leak, no explosion, no fire.
Heat abuse test	Put the battery in the high temperature test box, increase the temperature at 5°C/min, keep 130°C for 10 min, observe the battery.	Allow leak, no explosion, no fire.
Compulsive Discharge	Use a fully discharged battery in series with a 12V DC power supply and use the maximum continuous discharge current specified by the battery manufacturer as the initial current for forced discharge. After the test, observe the battery for 7d.	Allow leak, no explosion, no fire.

5 Test condition

5.1 Initial Test : Unless otherwise specified, routine performance testing must be completed within 45 days after receiving the batteries.

5.2 Temperature, Moisture and Atmosphere Pressure: Unless otherwise specified, tests shall be conducted at 25°C \pm 2°C, atmosphere pressure 88~106kPa and relative humidity 45%~75%.

5.3 Testing Instruments

5.3.1 Size Measurement Instrument : Vernier caliper with measurement error of no more than \pm 0.02mm or other size measurement instrument with equivalent accuracy.

5.3.2 Voltmeter : The DC voltmeter with an accuracy of no more than 0.5%, and its internal resistance is no less than 10 M Ω .

5.3.3 Precision resistance : Relative error is less than 0.5%.

5.3.4 Resistance box : Relative error is less than 0.5%.

5.3.5 Electric thermostatic drying oven : The absolute error is less than \pm 2°C.

6 Nameplate and Logo

The nameplate and logo of the battery should be kept clear, without falling off, and without obvious color difference.



6.1 Nameplate : The nameplate (trademark) of the battery includes the battery model, rated voltage, production date code, warning signs, etc.

6.2 Code writing : The battery production date code is represented by eight digits. The first four digits indicate the year, and the middle two digits indicate the month. The last two digits indicate the date. For example: the code "20200520" means that the battery was produced on May 20, 2020.

6.3 Mark of the extremes: Mark on the side of the battery, and use "+" and "-" to indicate the positive and negative ends of batteries.

7 Transportation

—During transportation, the battery should be protected from sunlight, fire, rain, water and corrosive substances.

—Shock and vibration during transportation and loading and unloading should be limited to a minimum.

—The stacking height of paper packaging boxes shall not exceed 1.5 meters.

—When the battery is transported over long distances, if it is transported by ship, it should be placed away from the engine; in summer, it should not be left in an unventilated environment for a long time.

8 Safety Precautions

Because this product has some hazards during transportation, storage and use, leakage or even explosion may occur when the operation is not correct. Before you use this product, please read this product specification carefully and keep it properly for reference.

—Batteries are strictly prohibited from over-discharging, squeezing and burning.

—It is strictly forbidden to short-circuit or charge the battery.

—It is strictly forbidden for users to disassemble the battery by themselves.

—It is strictly forbidden to use or heat outside the allowable temperature range.

—It is strictly forbidden to weld directly on the surface of the battery.

—It is strictly forbidden to use batteries with severe scars or deformation..

—It is strictly forbidden to use batteries with dry batteries or other primary batteries, and do not use batteries with different packages, different models or different brands.

—It is strictly forbidden to mix new and old batteries.

—When installing the device, make sure that the battery's positive and negative poles are not reversed.

—When the battery is used to the end voltage, it should be removed from the instrument in time.

—When not in use for a long time, remove the battery from the device and store it in a low



temperature and low humidity environment.

—To connect batteries in series and parallel, please contact our company.

—Used batteries should be disposed of in accordance with local environmental protection regulations.

—During use or storage, if the battery is found to have heat, odor, discoloration, deformation or other abnormalities, please stop using it.

9 Storage

—The battery should be used and stored in a place away from static electricity.

—The battery should be stored in an environment where the temperature does not exceed 30° C and the relative humidity is 45% to 75%.

—When storing the battery, keep it away from heat sources, do not place it in direct sunlight. Ensure that it is clean, cool, dry, ventilated, and not affected by climate.

—The stacking height of batteries depends on the packaging strength. Generally, the stacking height of paper packaging boxes should not exceed 1.5 meters, and the stacking height of wooden boxes should not exceed 3 meters.

—Batteries are stored and displayed in their original packaging. After the packaging is removed, the batteries cannot be stacked, which may cause short circuit and damage to the battery.

10 Usage Advise

—When the battery is used with the positive pole facing upwards, the energy utilization is the highest. It is recommended that the battery be placed upright when designing the battery compartment.

—The battery is suitable for use in a relatively cool environment. When used for a long time in a high temperature and high humidity environment, the service life will be reduced.

11 Declaration

If you have any questions about this product specification, please contact Wuhan Sunmoon Battery Co.,Ltd.. Wuhan Sunmoon Battery Co., Ltd. reserves the right to modify this product specification.



Figure 1 Structure diagram of lithium Manganese battery (Spiral type)

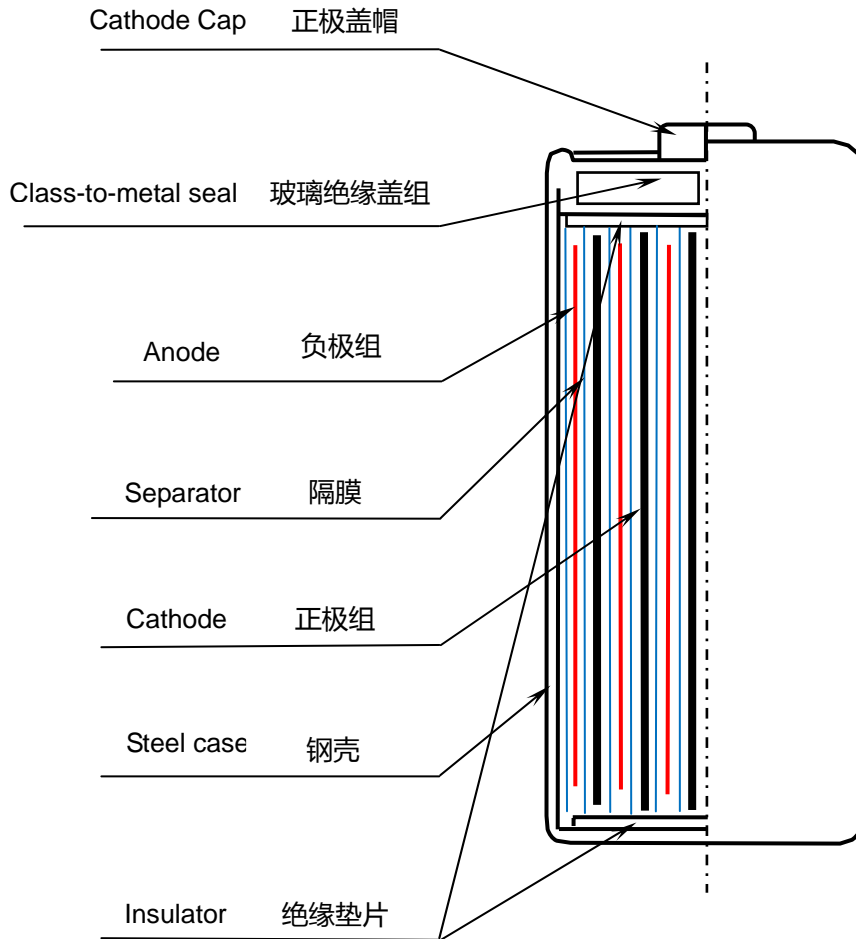

Figure 2 Discharge Curve of Single Cell

This specification is the company standard of Wuhan Sunmoon Battery Co., Ltd, without authorization, any pirated or transmit is prohibited.

Specification of Product



At room temperature, different discharge current as a function of discharge time

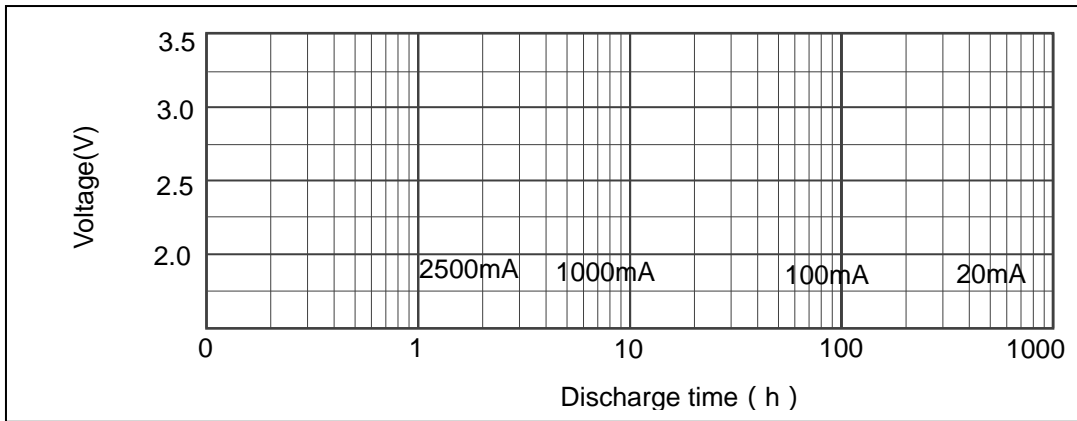

Discharge voltage, current as a function of temperature

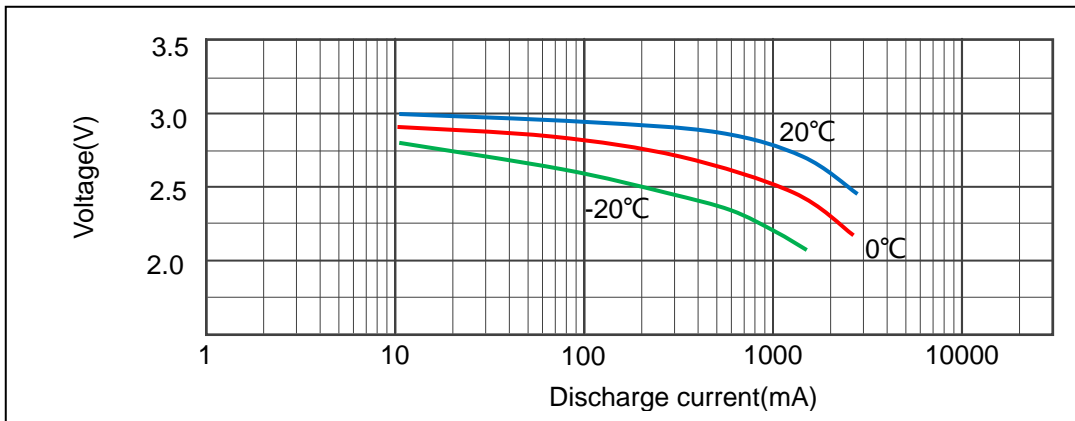

Discharge characteristics at different temperature (discharge current is 100mA)

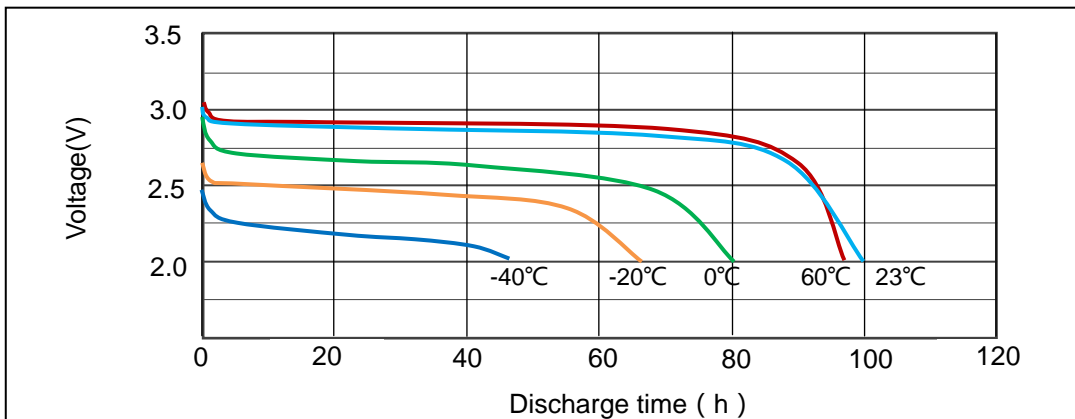
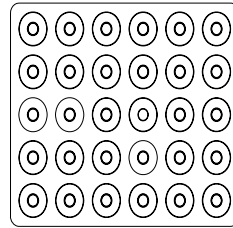

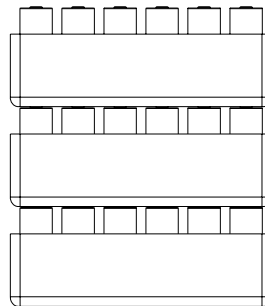

Figure 3 Packing

- 1) 30 cells per pallet.



- 2) 6 pallets per carton.



- 3) There are 180 cells per carton. Net weight: 23 kg. Gross weight: 24kg.

