

2.2 Environmental request

RoHS 2.0

HF 无卤素

REACH

其它

2.3 Functional description

- 1) Over-charge voltage protection
- 2) Over-discharge voltage protection
- 3) Over current protection
- 4) Short circuit protection

2.4 Mechanical characteristics

- 1) PCM Size: L 35(±0.15mm)×W 16.6(±0.1mm)×T 2.5 mm(MAX)
- 2) PCB Material/PCB: FR-4, 1 oz, 0.8±0.1mm
- 3) Layer: 2Layers
- 4) Plating Method: HASL LF
- 5) PSR INK: Green
- 6) SILK INK: White

2.5 Connecting description

Symbol	Description	Symbol	Description
P+	Battery output/charging positive pole	B+	Cell positive pole
P-	Battery output/charging negative pole	B-	Cell negative pole
BM	Connect Battery 1 negative, connect battery 2 positive		

2.6 Electrical characteristic

(Ta=25°C)

Contents	Min.	Type	Max.	Tolerance	Unit
Absolute Maximum Rating					
Input Charging Voltage		8.40			V
Input Charging Current			3		A
Output Discharging Voltage	5.80	7.40	8.56		V
Continuous Output Discharging Current			3		A
Ambient Condition					
Operating Temperature	-20		+85		°C
Humidity (No Water-Drop)	0%		80%		RH
PCM Storage Condition/PCM					
PCM Storage Temperature PCM	-55		+125		°C
Humidity (No Water-Drop)	45%		85%		RH
Protection Parameters					
Over-Charge Voltage Protection (OVP)	4225	4280	4305	±25	mV
Over-Charge Voltage Protection Release	4030	4080	4130	±50	mV

Over-Charge Voltage Protection Delay Time	700	1000	1300		mS
Over-Discharge Voltage Protection (UVP)	2820	2900	2980	±50	mV
Over-Discharge Voltage Protection Release	2900	3000	3100	±100	mV
Over-Discharge Voltage Protection Delay Time	70	110	150		ms
Over-Current Charge Protection Detection Voltage	-240	-210	-180	±30	mV
Over-Current Charge Protection (OCC)	8	11	14		A
Over-Current Charge Protection Delay Time	4	7	10		ms
Over-Current Discharge Protection Detection Voltage	185	200	215	±15	mV
Over-Current Discharge Protection (OCD)	7	10	13		A
Over-Current Discharge Protection Delay Time	8	12	16		ms
Short Circuit Protection (SCP)	Protected, No Exceptions				
Short Circuit Protection Delay Time	150	300	500		uS
Short Circuit Protection Release	Remove Load Or Connect Charger				
Current Consumption					
Normal Mode		4.0	8.0		uA
Other Parameters					
Impedance (B-&P-)		30	68		mΩ
Impedance (B+&P+)		-			mΩ
ID Resistor ID		-			KΩ
NTC Resistor NTC		-			KΩ
PTC Impedance PTC		-			mΩ
0V Battery Charge Function 0V	yes				
ESD Protection Function ESD	no				

3. SMT Diagram

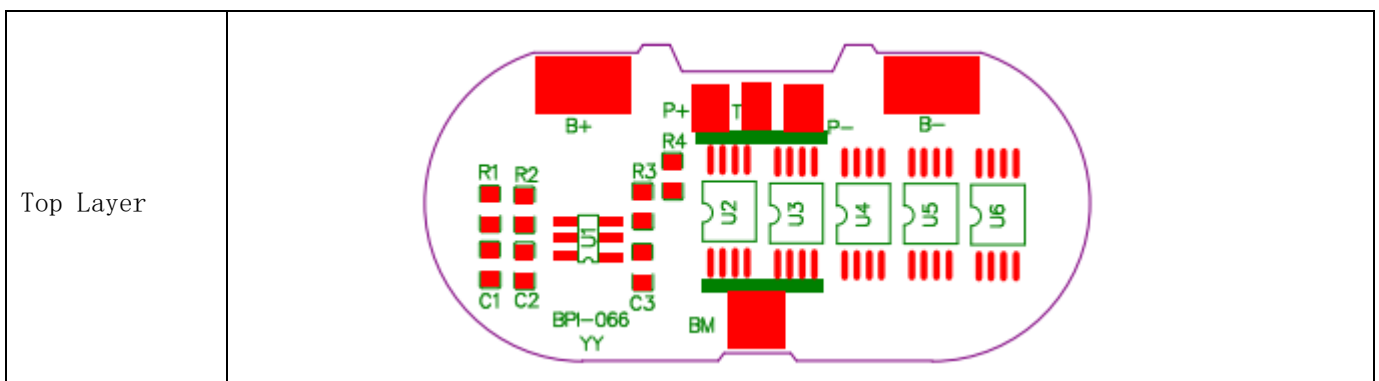

4. PCB Layout / PCB

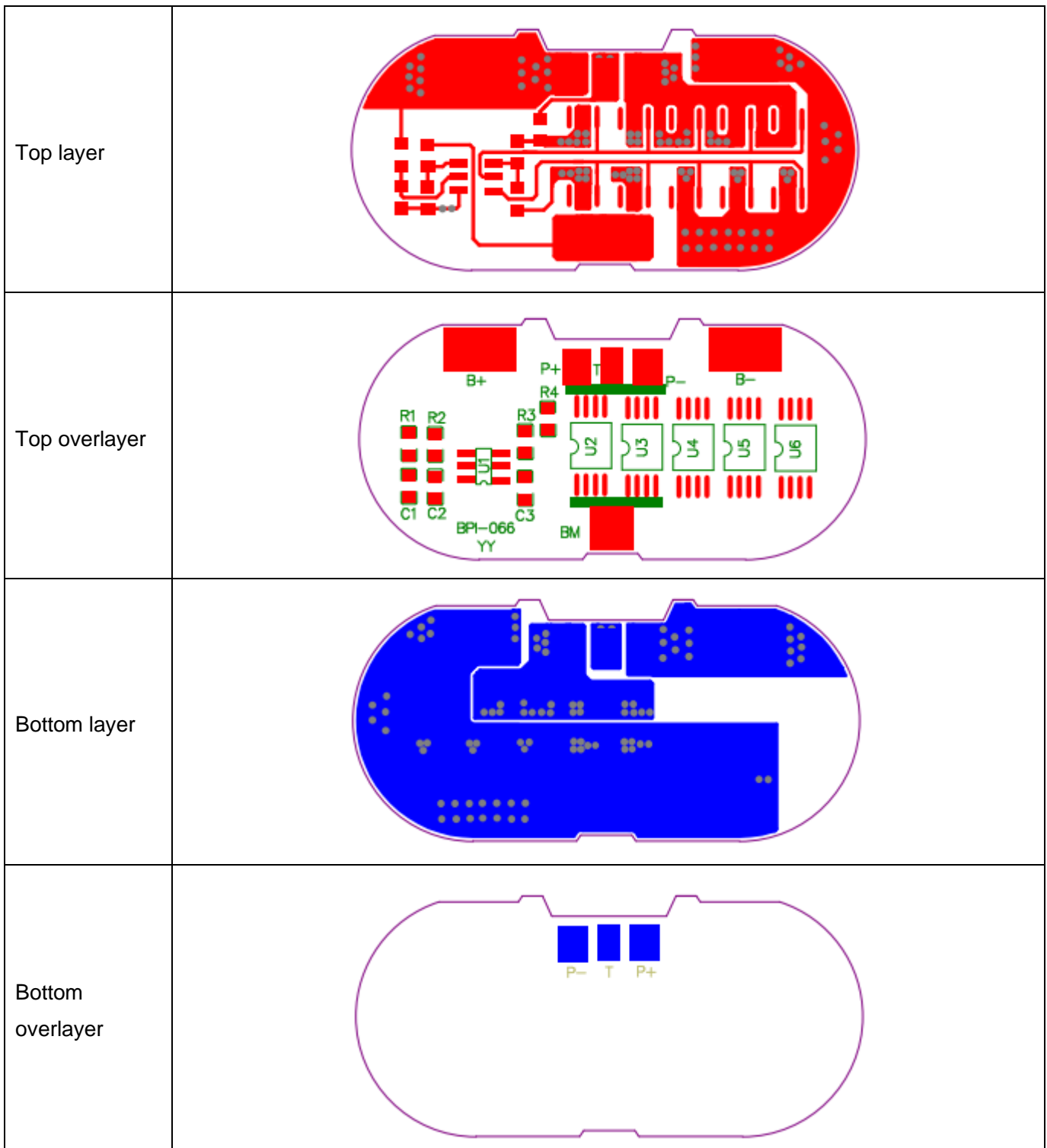

5.Electrical Schematic

1	Overcharge protection voltage	4.28±0.025V	4.275	4.277	4.282	4.278	4.277	OK
2	Overcharge protection delay time	MAX 1300ms	1025	1024	1080	1066	1109	OK
3	Overdischarge protection voltage	2.90±0.08V	2.890	2.892	2.890	2.895	2.895	OK
4	Overdischarge protection delay time	MAX150ms	124	126	124	125	125	OK
5	Discharge overcurrent protection current	7-13A	9.58	9.55	9.62	9.50	9.50	OK
6	Static current	≤8.0 uA	4.5	4.5	4.5	4.5	4.6	OK
7	Impedance (B-&P-)	≤68mΩ	28	28	29	28	29	OK

8.2 Environmental Requirements

The specification subjects to the EU Directive about RoHS 2.0, and the hazardous substance conforms to the following standard.

Hazardous substance	Standard (mg/KG)	Remarks
(Cd)	<100	
(Pb)	<1000	
(Hg)	<1000	
(Cr6+)	<1000	
(PBBs)	<1000	
(PBDEs)	<1000	
(DBP)	<1000	
(BBP)	<1000	
(DIBP)	<1000	
(DEHP)	<1000	

Declaration: the above standard is the requirements of EU RoHS 2.0 Directive, we will base on the customer's requirements when it is stricter than the EU standard.