

Lithium elements

Product specification

2.2 Environmental request

RoHS 2.0

HF 无卤素

REACH

其它

2.3 Functional description

- 1) Over-charge voltage protection
- 2) Over-discharge voltage protection
- 3) Over current protection
- 4) Short circuit protection

2.4 Mechanical characteristics

- 1) PCM Size: L 35(±0.15mm)×W 16.6(±0.1mm)×T 2.5 mm(MAX)
- 2) PCB Material/PCB: FR-4, 1 oz, 0.8±0.1mm
- 3) Layer: 2Layers
- 4) Plating Method: HASL LF
- 5) PSR INK: Green
- 6) SILK INK: White

2.5 Connecting description

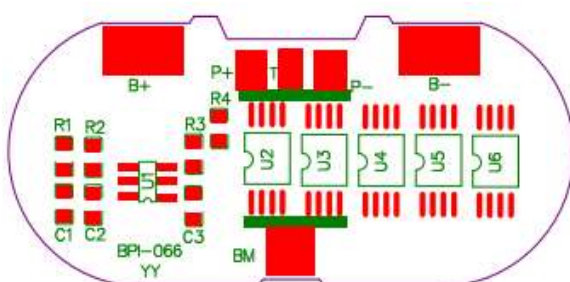

Symbol	Description	Symbol	Description
P+	Battery output/charging positive pole	B+	Cell positive pole
P-	Battery output/charging negative pole	B-	Cell negative pole
BM	Connect Battery 1 negative, connect battery 2 positive		

2.6 Electrical characteristic

(Ta=25°C)

Contents 内容	Min.	Type	Max.	Tolerance	Unit
Absolute Maximum Rating					
Input Charging Voltage		7.20			V
Input Charging Current			4		A
Output Discharging Voltage	4.00	6.40	7.30		V
Continuous Output Discharging Current			4		A
Ambient Condition					
Operating Temperature	-20		+85		°C
Humidity (No Water-Drop)	0%		80%		RH
PCM Storage Condition/PCM					
PCM Storage Temperature PCM	-55		+125		°C
Humidity (No Water-Drop)	45%		85%		RH
Protection Parameters					
Over-Charge Voltage Protection (OVP)	3625	3650	3675	±25	mV
Over-Charge Voltage Protection Release	3400	3450	3500	±50	mV
Over-Charge Voltage Protection Delay Time	700	1000	1300		mS
Over-Discharge Voltage Protection (UVP)	1920	2000	2080	±50	mV
Over-Discharge Voltage Protection Release	2400	2500	2600	±100	mV
Over-Discharge Voltage Protection Delay Time	70	110	150		ms
Over-Current Charge Protection Detection Voltage	-230	-200	-170	±30	mV
Over-Current Charge Protection (OCC)	13	16	19		A
Over-Current Charge Protection Delay Time	4	7	10		ms
Over-Current Discharge Protection Detection Voltage	170	200	230	±30	mV
Over-Current Discharge Protection (OCD)	13	16	19		A
Over-Current Discharge Protection Delay Time	6	10	14		ms
Short Circuit Protection (SCP)	Protected, No Exceptions				
Short Circuit Protection Delay Time	150	300	500		uS
Short Circuit Protection Release	Remove Load Or Connect Charger				
Current Consumption					
Normal Mode		4.0	8.0		uA
Other Parameters					
Impedance (B-&P-)		40	68		mΩ
Impedance (B+&P+)		-			mΩ
ID Resistor ID		-			KΩ
NTC Resistor NTC		-			KΩ
PTC Impedance PTC		-			mΩ
0V Battery Charge Function 0V	允许				
ESD Protection Function ESD	无				

4. SMT Diagram

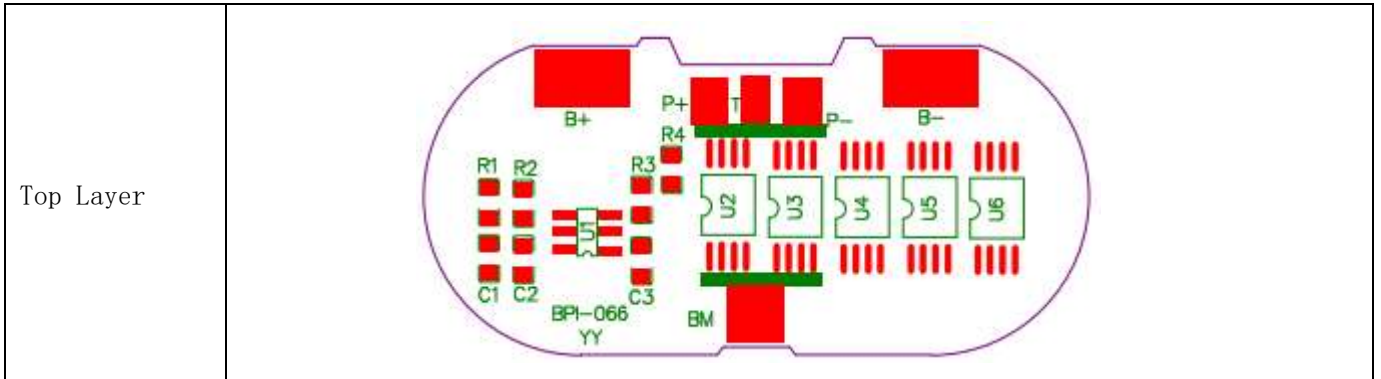

5. PCB Layout / PCB

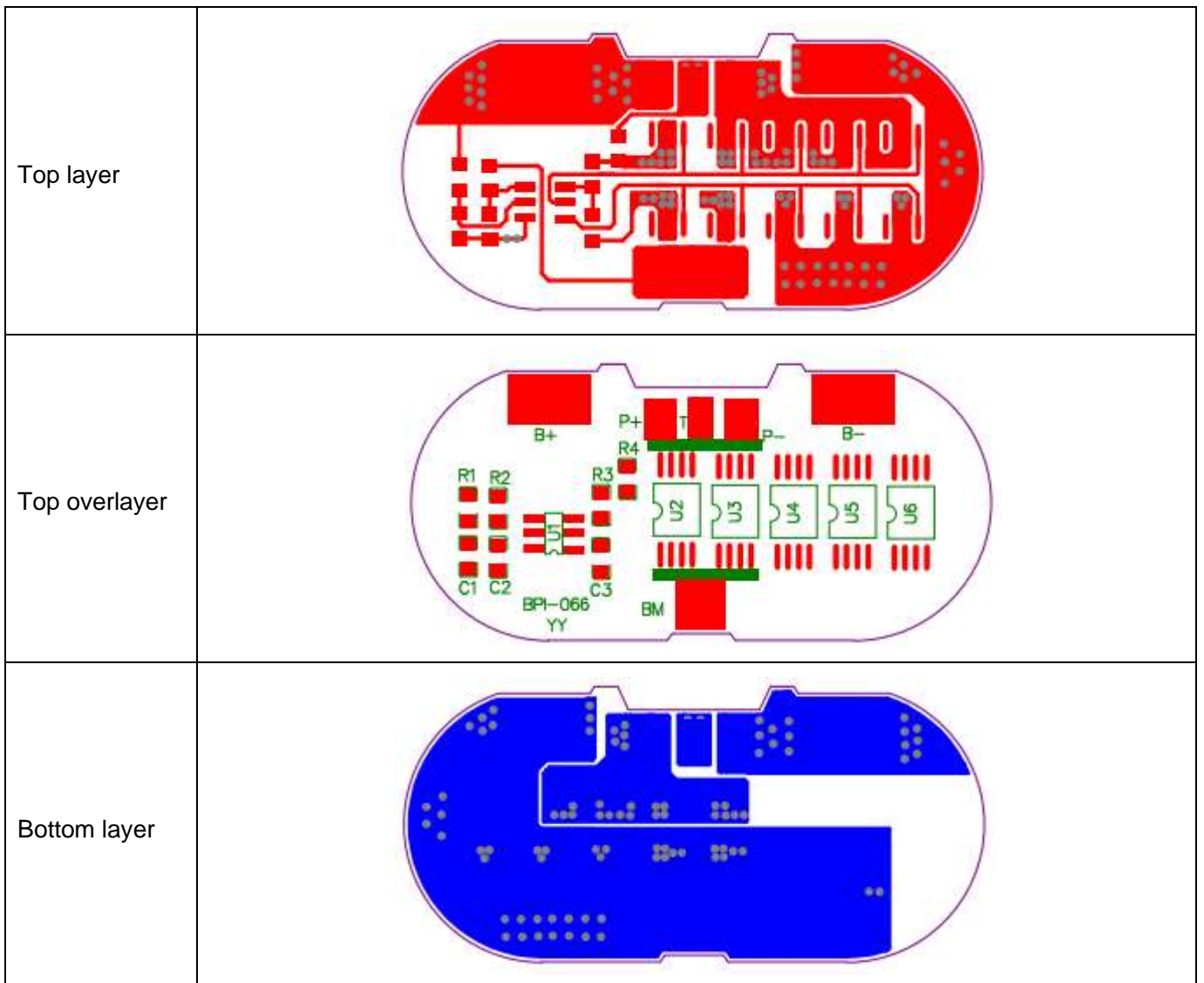

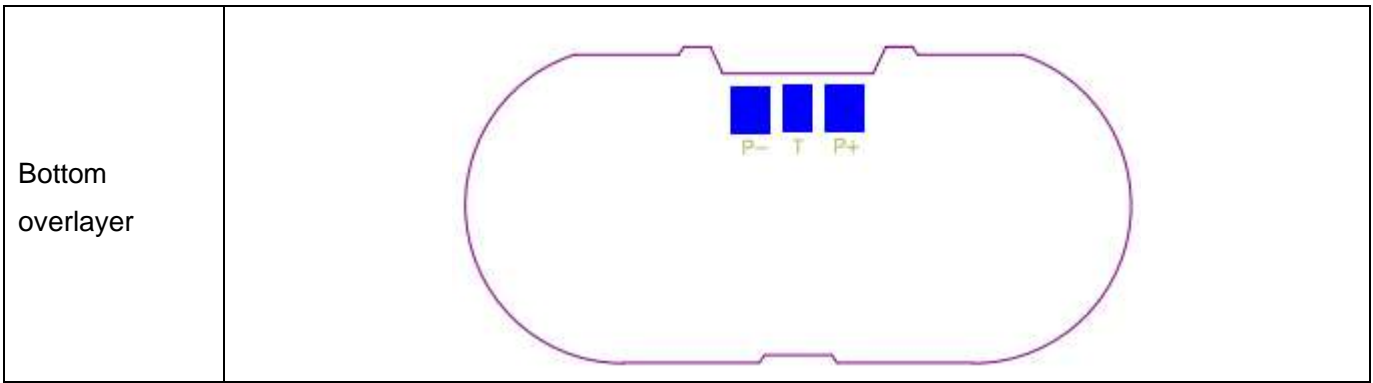

6. Electrical Schematic

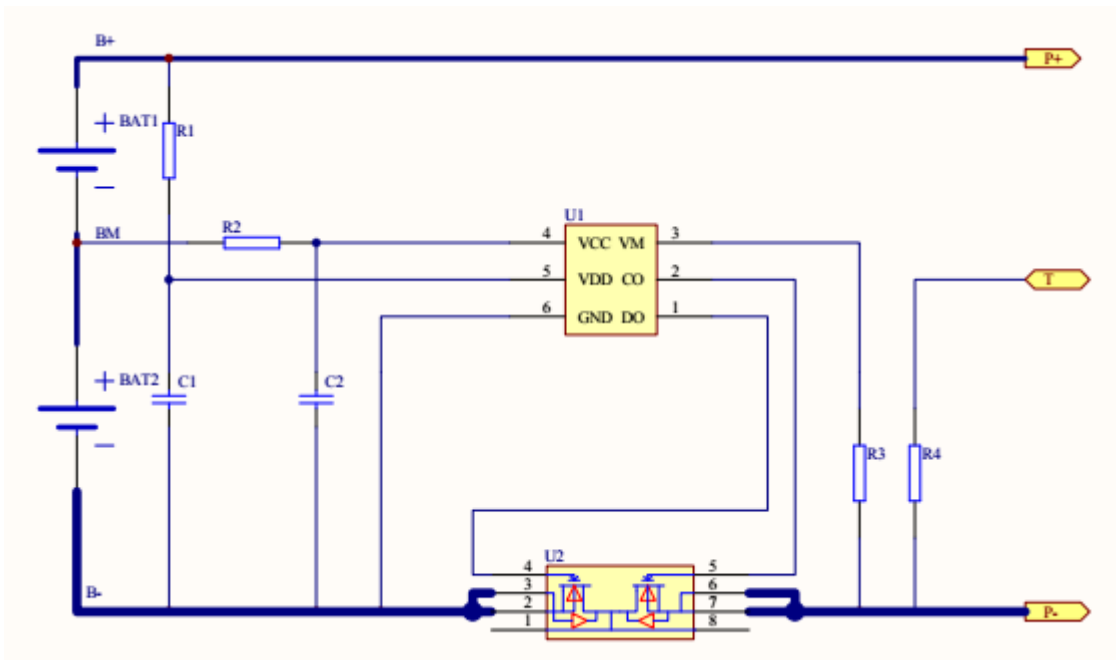

7. PCB diagram / PCB

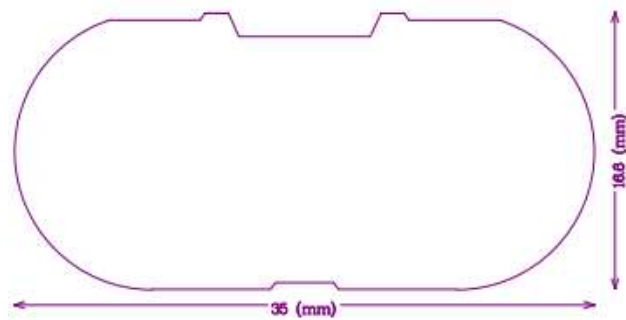

8.2 Storage

8.2.1 Storage Temperature : $23 \pm 5^{\circ}\text{C}$

8.2.2 Storage Humidity: $45 \pm 15\% \text{ RH}$

8.2.3 Should pay attention to ESD

8.3 Transportation

8.3.1 Delivery to your storhouse by express or our deliveryman.

8.3.2 Should pay attention to moisture, moisture, avoid extrusion, impact, etc., to prevent damage to the PCM during transportation.

9. Attachment

9.1 Sample test data

NO.	Test Project	Test standard	Test Value					Judgment
			1	2	3	4	5	
1	Overcharge protection voltage	3.65±0.025V	3.648	3.649	3.648	3.648	3.649	OK
2	Overcharge protection delay time	MAX 1300ms	1024	1056	1080	1109	1066	OK
3	Over discharge protection voltage	2.00±0.08V	1.998	1.995	1.997	1.999	1.999	OK
4	Over discharge protection delay time	MAX150ms	124	126	126	124	128	OK
5	Discharge over current protection current	13-19A	16.9	17.0	16.5	16.8	16.9	OK
6	Static current	≤8.0 uA	4.7	4.8	4.8	4.7	4.8	OK
7	Impedance (B-&P-)	≤68mΩ	35	38	38	37	36	OK

9.2 Environmental Requirements

The specification subjects to the EU Directive about RoHS 2.0, and the hazardous substance conforms to the following standard.

Hazardous substance	Standard (mg/KG)	Remarks
(Cd)	<100	
(Pb)	<1000	

(Hg)	<1000	
(Cr6+)	<1000	
(PBBs)	<1000	
(PBDEs)	<1000	
(DBP)	<1000	
(BBP)	<1000	
(DIBP)	<1000	
(DEHP)	<1000	

Declaration: the above standard is the requirements of EU RoHS 2.0 Directive, we will base on the customer's requirements when it is stricter than the EU standard.