

Lithium elements

Product specification

2.2 Environmental request

RoHS 2.0

HF 无卤素

REACH

其它

2.3 Functional description

- 1) Over-charge voltage protection
- 2) Over-discharge voltage protection
- 3) Over current protection
- 4) Short circuit protection

2.4 Mechanical characteristics

- 1) PCM size: L 53.57(±0.2mm)×W 16.07(±0.15mm)×T 4.5mm(MAX)
- 2) PCB MATERIA/PCBL: FR-4, 1 oz,1.0±0.10mm
- 3) LAYER/: 2Layers
- 4) Plating Method:: HASL LF
- 5) PSR INK: GREEN ,
- 6) SILK INK/: White

2.5 Connecting description

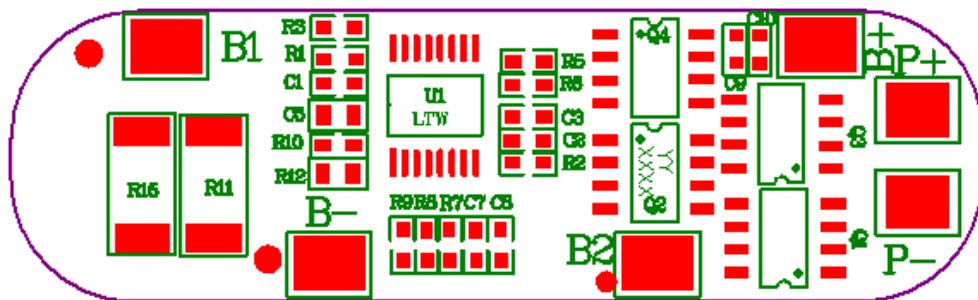

XXXXXXXXXXXXXXXXXXXX

Symbol	Description	Symbol	Description
P+	Battery output/charging positive pole	B+	3Cell positive pole
P-	Battery output/charging negative pole	B2	2Cell positive pole
B1	1Cell positive pole	B-	1Cell negative pole

2.6 Electrical characteristic

(Ta=25°C)

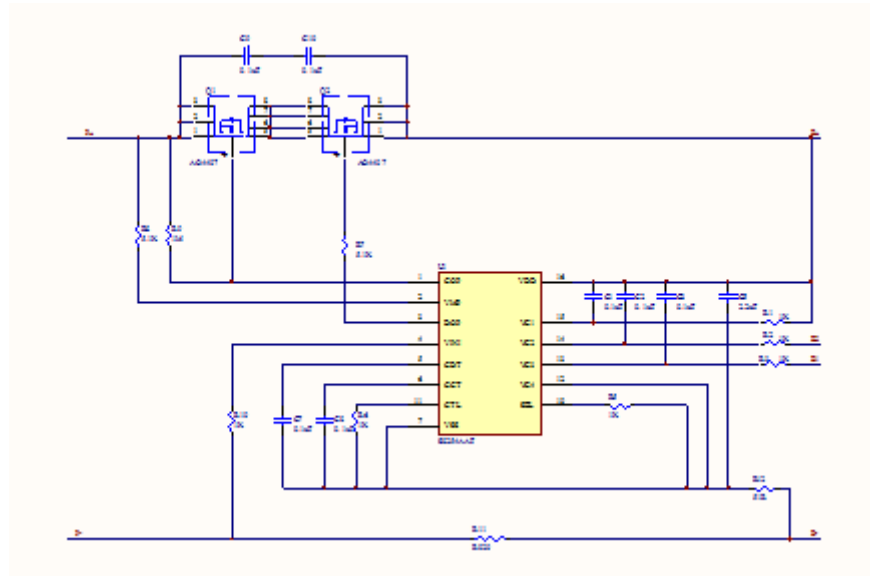

Contents	Min.	Type	Max.	Tolerance	Unit
Absolute Maximum Rating					
Input Charging Voltage		12.6			V
Input Charging Current			6		A
Output Discharging Voltage	8.1	11.1	12.75		V
Continuous Output Discharging Current			6		A
Ambient Condition					
Operating Temperature	-40		+85		°C
Humidity (No Water-Drop)	0%		80%		RH
PCM Storage Condition/PCM					
PCM Storage Temperature PCM	-55		+125		°C
Humidity (No Water-Drop)	45%		85%		RH
Protection Parameters					
Over-Charge Voltage Protection (OVP)	4225	4250	4275	±25	mV
Over-Charge Voltage Protection Release	4100	4150	4200	±50	mV
Over-Charge Voltage Protection Delay Time	500	1500	2000		mS
Over-Discharge Voltage Protection (UVP)	2620	2700	2780	±80	mV
Over-Discharge Voltage Protection Release	2900	3000	3100	±100	mV
Over-Discharge Voltage Protection Delay Time	50	100	200		mS
Over-Current Charge Protection Detection Voltage	/	/	/		mV
Over-Current Charge Protection (OCC)	/	/	/		A
Over-Current Charge Protection Delay Time	/	/	/		mS
Over-Current Discharge Protection Detection Voltage	175	200	225		mV
Over-Current Discharge Protection (OCD)	15	20	25		A
Over-Current Discharge Protection Delay Time	5	10	15		ms
Short Circuit Protection Detection Voltage (SCP)	1175	1200	1225		mV
Short Circuit Protection Delay Time	100	300	500		uS
Short Circuit Protection Release	Remove Load Or Connect Charger				
Current Consumption					
Normal Mode		20	40		uA
Other Parameters					
Impedance		40	65		mΩ
0V Battery Charge Function 0V	No				
ESD Protection Function ESD	No				

4. Diagram

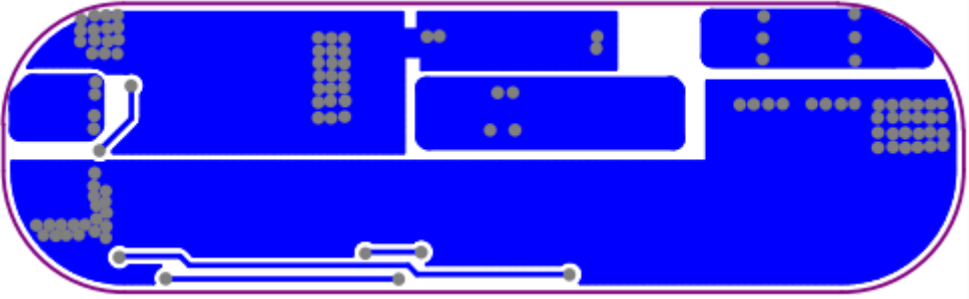

5.PCB Layout / PCB

<p>Top layer</p>	<p>The image shows the top layer of a PCB layout. The entire surface is colored red, representing the copper. White traces represent the conductive paths for the circuit. Various components are placed on the board, including a central chip labeled 'U1 LTW', several resistors (R1-R100), and capacitors (C1-C100). The layout is symmetrical and follows the same footprint as the schematic above.</p>
<p>Top overlayer</p>	<p>The image shows the top overlayer of the PCB layout. The background is green, and the components are outlined in green. The components are labeled with their respective designations: B1, B2, B3, B4, B5, B6, B7, B8, B9, B10, B11, B12, B13, B14, B15, B16, B17, B18, B19, B20, B21, B22, B23, B24, B25, B26, B27, B28, B29, B30, B31, B32, B33, B34, B35, B36, B37, B38, B39, B40, B41, B42, B43, B44, B45, B46, B47, B48, B49, B50, B51, B52, B53, B54, B55, B56, B57, B58, B59, B60, B61, B62, B63, B64, B65, B66, B67, B68, B69, B70, B71, B72, B73, B74, B75, B76, B77, B78, B79, B80, B81, B82, B83, B84, B85, B86, B87, B88, B89, B90, B91, B92, B93, B94, B95, B96, B97, B98, B99, B100. The central chip is labeled 'U1 LTW'. The layout is symmetrical and follows the same footprint as the schematic above.</p>

Bottom layer	
Bottomoverlayer	

7.PCB diagram / PCB

9.2 Storage

9.2.1 Storage Temperature : $23\pm 5^{\circ}\text{C}$

9.2.2 Storage Humidity : $45\pm 15\%$ RH

9.2.3 Should pay attention to ESD

9.3 Transportation

9.3.1 Delivery to your storhouse by express or our deliveryman.

9.3.2 Should pay attention to moisture, moisture, avoid extrusion, impact, etc., to prevent damage to the PCM during transportation.

10. Attachment

10.1 Sample test data

NO.	Test Project	Test standard	Testing Vale					Judgment
			1	2	3	4	5	
1	Overcharge protection voltage	4.25±0.025V	4.252	4.253	4.252	4.250	4.249	OK
2	Overdischarge protection voltage	2.70±0.08V	2.699	2.702	2.701	2.703	2.702	OK
3	Overdischarge protection voltage	15-25A	17.8	17.7	17.9	17.5	17.5	OK
4	Static current	≤40.0 uA	22.5	24.4	24.4	24.5	24.5	OK
5	Impedance (B-&P-)	≤65mΩ	20	21	18	17	18	OK

10.2 Environmental Requirements

The specification subjects to the EU Directive about RoHS 2.0, and the hazardous substance conforms to the following standard.

Hazardous substance	Standard (mg/KG)	Remarks
(Cd)	<100	
(Pb)	<1000	
(Hg)	<1000	
(Cr6+)	<1000	
(PBBs)	<1000	
(PBDEs)	<1000	
(DBP)	<1000	
(BBP)	<1000	
(DIBP)	<1000	
(DEHP)	<1000	

Declaration: the above standard is the requirements of EU RoHS 2.0 Directive, we will base on the customer's requirements when it is stricter than the EU standard.