

Lithium elements

Product specification

2.2 Environmental request

RoHS 2.0

HF 无卤素

REACH

其它

2.3 Functional description

- 1) Over-charge voltage protection
- 2) Over-discharge voltage protection
- 3) Over current protection
- 4) Short circuit protection

2.4 Mechanical characteristics

- 1) PCM size: L 62(±0.15mm)×W32(±0.15mm)×T 3.8mm(MAX)
- 2) PCB MATERIA/PCB L: FR-4, 1 oz 1.6±0.1mm
- 3) LAYER: 2Layers
- 4) Plating Method: HASL LF
- 5) PSR INK: Green
- 6) SILK INK: White

2.5 Connecting description

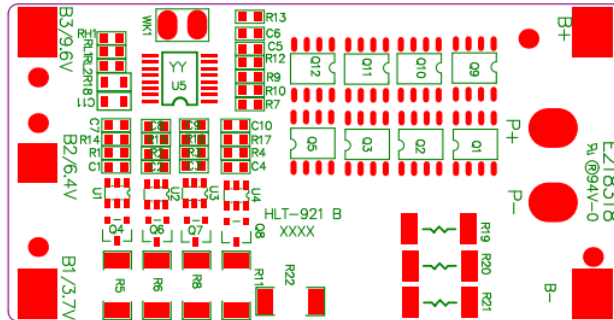

Symbol	Description	Symbol	Description
P+	Battery output/charging positive pole	B+	4Cell positive pole
P-	Battery output/charging negative pole	B3	3Cell positive pole
B2	2Cell positive pole	B1	1Cell positive pole
		B-	1Cell negative pole

2.6 Electrical characteristic

(Ta=25°C)

Contents	Min.	Type	Max.	Tolerance	Unit
Absolute Maximum Rating					
Input Charging Voltage		16.8			V
Input Charging Current			4		A
Output Discharging Voltage	10.8	14.8	17		V
Continuous Output Discharging Current			6		A
Ambient Condition					
Operating Temperature	-40		+85		°C
Humidity (No Water-Drop)	0%		80%		RH
PCM Storage Condition/PCM					
PCM Storage Temperature PCM	-55		+125		°C
Humidity (No Water-Drop)	45%		85%		RH
Protection Parameters					
Over-Charge Voltage Protection (OVP)	4225	4250	4275	±25	mV
Over-Charge Voltage Protection Release	4100	4150	4200	±50	mV
Over-Charge Voltage Protection Delay Time	500	1000	1500		mS
Over-Discharge Voltage Protection (UVP)	2620	2700	2780	±80	mV
Over-Discharge Voltage Protection Release	2900	3000	3100	±100	mV
Over-Discharge Voltage Protection Delay Time	50	100	200		mS
Over-Current Charge Protection Detection Voltage	/	/	/		mV
Over-Current Charge Protection (OCC)	/	/	/		A
Over-Current Charge Protection Delay Time	/	/	/		mS
Over-Current Discharge Protection Detection Voltage	175	200	225	±25	mV
Over-Current Discharge Protection (OCD)	9	13	17		A
Over-Current Discharge Protection Delay Time	5	10	20		ms
Short Circuit Protection Detection Voltage (SCP)	400	500	600		mV
Short Circuit Protection Delay Time	100	300	600		uS
Short Circuit Protection Release	Remove Load Or Connect Charger				
Current Consumption					
Normal Mode			40		uA
Other Parameters					
Impedance (B-&P-)			40		mΩ
Voltage balance	/	/	/		V
Current balance	/	/	/		mA
0V Battery Charge Function 0V	Yes				
ESD Protection Function ESD	No				

4. SMT Diagram

<p>Top Layer</p>	
------------------	--

5.PCB Layout / PCB

<p>Top layer</p>	
<p>Top over layer</p>	
<p>Bottom layer</p>	
<p>Bottom overlayer</p>	

6. Electrical Schematic

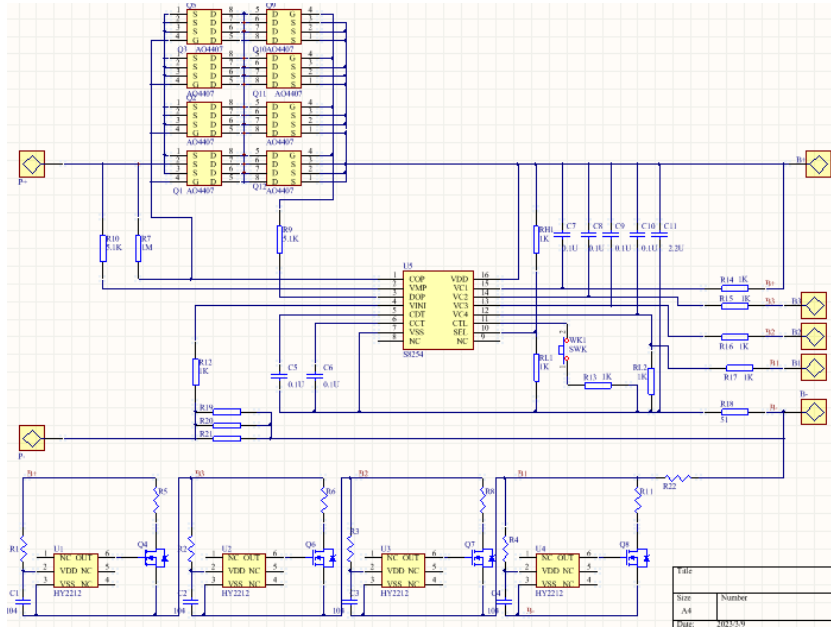

7.PCB diagram / PCB



8.2.1 Storage Temperature : 23±5°C

8.2.2 Storage Humidity : 45±15% RH

8.2.3 Should pay attention to ESD .

8.3 Transportation

8.3.1 Delivery to your storhouse by express or our deliveryman.

8.3.2 Should pay attention to moisture, moisture, avoid extrusion, impact, etc., to prevent damage to the PCM during transportation.

Declaration: the above standard is the requirements of EU RoHS 2.0 Directive, we will base on the customer’s requirements when it is stricter than the EU standard.